

# Next-Generation Networks

## Definition

The next-generation network seamlessly blends the public switched telephone network (PSTN) and the public switched data network (PSDN), creating a single multiservice network. Rather than large, centralized, proprietary switch infrastructures, this next-generation architecture pushes central-office (CO) functionality to the edge of the network. The result is a distributed network infrastructure that leverages new, open technologies to reduce the cost of market entry dramatically, increase flexibility, and accommodate both circuit-switched voice and packet-switched data.

## Overview

This tutorial explains the evolution of the next-generation switching architecture and highlights the superior features of this emerging technology.

### 1. Introduction

Throughout the telecommunications marketplace, a trend toward deregulation and liberalization prompted expectations of increased competition, reduced consumer prices, and innovative new services. Although many hailed the U.S. Telecommunications Act of 1996 as the beginning of a new age of innovative and affordable services, consumers have yet to witness any substantial new service offerings or savings in their monthly bills.

If the promise of lower costs and new service offerings has not been realized in the marketplace, the industry must ask why. The answer lies not in the halls of government but in the CO facilities of service providers. The rules have changed, but the infrastructure has not.

A company that can provide next-generation switch architecture can capitalize on the potential in this area of the market. In turn, a whole new area of commerce within the telecommunications arena will be created.

### 2. Historical Overview

#### Architecture Limitations

While the stage has been set for a new competitive landscape, the existing network architecture has prevented its full realization. In many markets where competitive local exchange carriers (CLECs) are challenging incumbent local exchange carriers (ILECs), services are merely resold by means of the existing infrastructure. In fact, industry experts estimate that more than 90 percent of all CLEC access lines are passively resold. Facility-based CLECs attempting to build new networks have been hampered by the high cost of large, proprietary Class-5 switches. With a typical up-front cost of \$3 million per deployment, traditional switch technology has prevented CLECs and other next-generation service providers from significantly altering the cost models long employed by the ILECs.

The existing proprietary Class-5 switching infrastructure has also hampered service providers' ability to create and deploy innovative new services to gain a competitive advantage. The proprietary architectures of the existing switch platforms have made network operators entirely dependent on switch vendors for new software applications and upgrades. These software upgrades and new services often take years to

develop, are extremely expensive, and remain the exclusive property of the switch manufacturer. This makes it difficult for service providers to differentiate themselves and limits the services available to consumers.

## Network Transformation

Today, however, the U.S. telecommunications market is poised to enter a new era of competition—an era that realizes what the Telecommunications Act of 1996 promised but did not deliver. The PSTN will be transformed as voice, data, and enhanced services converge. A new network architecture is about to emerge, driven by new technologies, new demand, and increased competition.

Today's network is divided into two elements: the PSTN and the PSDN (see Figure 1). The PSTN consists of large, centralized, proprietary Class-5 switches with remote switching modules (RSMs) and digital loop carriers (DLCs). This architectural configuration, representing \$250 billion in network investment and hundreds of billions of dollars in annual service revenues, has changed little over the last several decades.

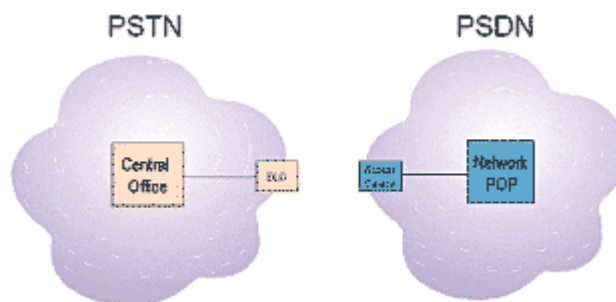

Figure 1. The PSTN and PSDN

In contrast, the substantially smaller PSDN—consisting of network points of presence (PoPs) and remote access devices—is growing at a dramatic rate. The growth of the PSDN is driven by the Internet, intranets, virtual private networks (VPNs), and remote access. However, the PSTN continues to be the principal means of delivering data services. According to Dataquest, 46.5 million analog modems will be sold in the year 2000; nearly all personal computers (PCs) purchased today come equipped with a 56-kbps modem.

Many industry pundits claim that packet-switched voice will displace circuit-switched voice in a matter of a few years. Despite the hype, however, voice over Internet protocol (VoIP) has yet to establish itself to any significant degree. Furthermore, if packetized voice is actually to displace circuit-switched voice, a decade or more will be necessary. In fact, the March 1999 edition of the Pulver Report estimates that in the current \$400 billion global minute's marketplace, 1999 revenues for IP-telephony minutes will be less than \$150 million.

Some form of convergence between the PSTN and the emerging PSDN is inevitable. The trouble is, no one is precisely certain about how and when this convergence will take place. Nevertheless, two points seem clear:

- With the existing CO switch infrastructure representing a multibillion-dollar investment, it is unlikely operators will opt for a wholesale replacement any time soon.

- While packet-switched technologies like IP and asynchronous transfer mode (ATM) will dominate in transport applications and are well-suited for Class-4/toll circuit switching, Class-5 time division multiplexing (TDM) will be required in the network for some time. Class-5 switching will become more distributed, reside at the edge of the network, and become integrated with enhanced service offerings.

In other words, circuit switching and packet switching will coexist for quite a while, with IP, ATM, and TDM all playing complementary roles.

### 3. A New Architecture

Against this evolving network landscape, a new network architecture—one that will blend the PSTN and PSDN—is emerging.

This shift is strikingly similar to the change that occurred in corporate information processing during the last decade. Economics and breakthrough technology combined to alter the data networking architecture completely. Instead of networks based on large, centralized, expensive mainframes and dumb terminals, today's distributed networks are made up of low-cost, smart desktop computers linked together. This transformation has permitted applications to be pushed closer to the end-user, reducing overall cost while greatly enhancing system flexibility and functionality (see *Figure 2*).

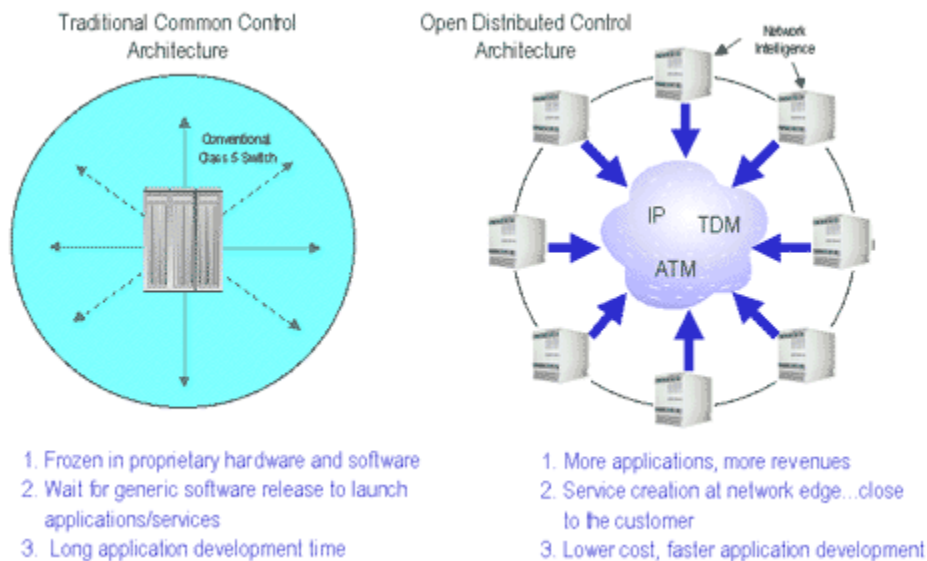

Figure 2. Distributed Control Architecture

In other words, this new generation of low-cost, open switching platforms has the potential to transform the telecommunications service market in the same way that the desktop personal computer (PC) changed the corporate computing landscape. Large, centralized, Class-5 proprietary switches will continue to play a significant role in the network, but distributed, open, and programmable Class-5 access and enhanced services platforms will play a dominate role in altering the network landscape.

## The Missing Link

Instrumental to the success of this transformation is new next-generation architecture, purposely constructed to provide the missing link between the PSTN and the PSDN (see *Figure 3*).

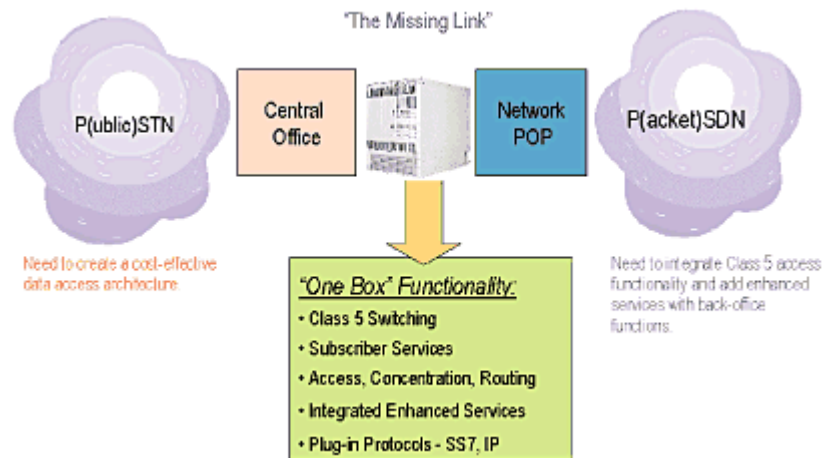

Figure 3. The Missing Link in Network Convergence

This next-generation switching architecture represents an entirely new approach to delivering services that is specifically designed to accomplish the following services:

- deliver robust switching functionality at a cost that is an order of magnitude lower than traditional, proprietary Class-5 switches
- distribute switching functionality to the edge of the network
- protect existing investments by supporting all current analog and digital network standards, interfaces, media, and service elements
- reduce the number of network elements by combining a range of telephony, application, and service-delivery functions
- enable new service creation through programmability and the flexibility of an open application programming interface (API)
- provide a high degree of scalability, enabling network operators to expand their subscriber base rapidly and cost-effectively
- promote extensibility through open architecture design and, thus, take advantage of future technological advances
- redefine true, carrier-class design for maximum fault tolerance and zero downtime
- reduce operating costs by employing advanced remote maintenance and diagnostics capabilities.
- increase revenues by shortening time to market, reducing upfront costs, and providing remote management capabilities

Clearly, this approach represents a dramatic departure from traditional switch architecture. The differences in a side-by-side comparison are immediately apparent (see *Table 1*).

<b>Traditional Class-5 Switch</b>	<b>Next-Generation Switch</b>
\$3 million startup	\$100,000 startup
Hub and spoke switching	Distributed switching
Remote Switching Modules (RSMs) and Digital Loop Carriers (DLCs)	ATM and/or IP core switching and backbones
Adjunct boxes for enhanced services	Class-5 access device with integrated enhanced and data services
Separate data network boxes	

Table 1. Traditional versus Next-Generation Switch

#### 4. The Next-Generation Switch

Next-generation switches are the most flexible platforms available. Combining extreme scalability, an open service creation environment (SCE), remote management and diagnostics, and the highest availability, next-generation switches provide a migration path from today's switching architecture to a more cost-effective, efficient, next-generation network architecture.

##### Extreme Scalability

Next-generation switches are purpose-built to scale to meet the needs of any subscriber base (see *Figure 4*). These systems are designed to have a small start-up cost and a linear incremental cost. This architecture allows carriers to make better use of their capital by purchasing only the capacity that their network requires; as carriers need additional capacity, additional cards can be inserted.

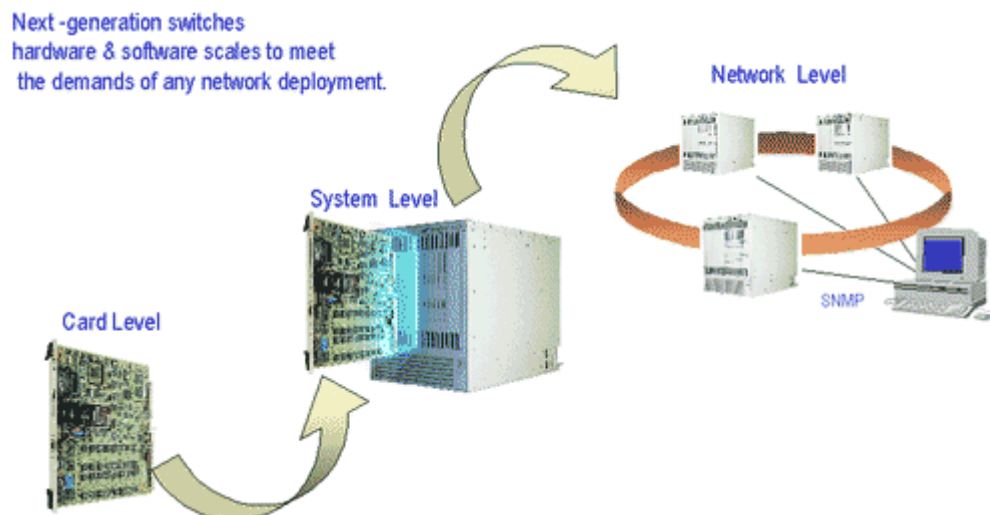

Figure 4. Scalability of Next-Generation Switches

## Service Creation Environment

To compete and win in a competitive environment, carriers must offer revenue-generating enhanced services ahead of the competition. Another benefit of next-generation switches is their rich SCE. Typically a graphical user interface, these SCEs allow carriers to develop, deploy and—most importantly—pay only for the services that their customers require (see Figure 5). In an era of next-generation switches, carriers will no longer need to wait for a vendor's next generic release of feature software. Instead, the carriers or third-party developers can quickly and cost-effectively develop their own applications. Doing so will provide yet another competitive advantage. The carrier will own its new applications, thereby limiting a competitor's ability to offer the same service.

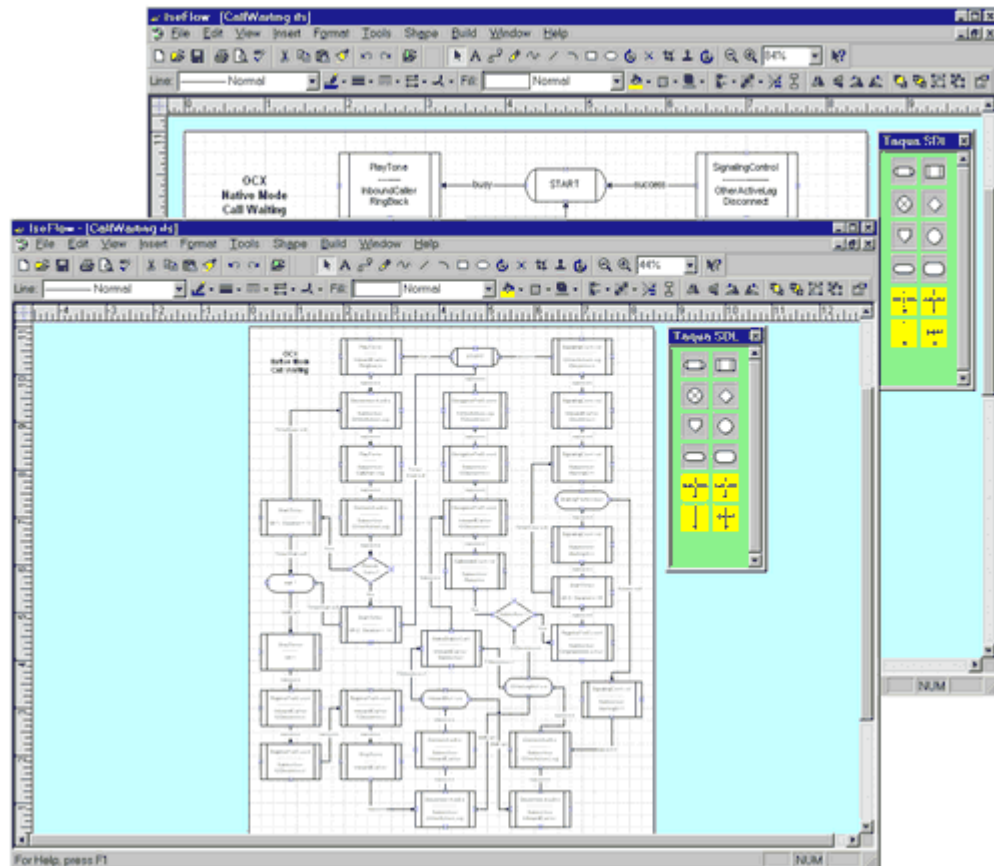

Figure 5. Service Creation Environment

## Remote Management and Diagnostics

Next-generation switches allow carriers to connect a distributed network of intelligent switches together and manage them as a single virtual switch. These platforms come equipped with revolutionary graphical user interface software modules that allow carriers to manage and provision their network remotely. Next-generation switches give carriers the ability to gain access to a specific resource on a specific card via a host computer connected to the next-generation network. This capability greatly reduces a network operator's costs by eliminating expensive truck rolls and costly service calls (see Figure 6).

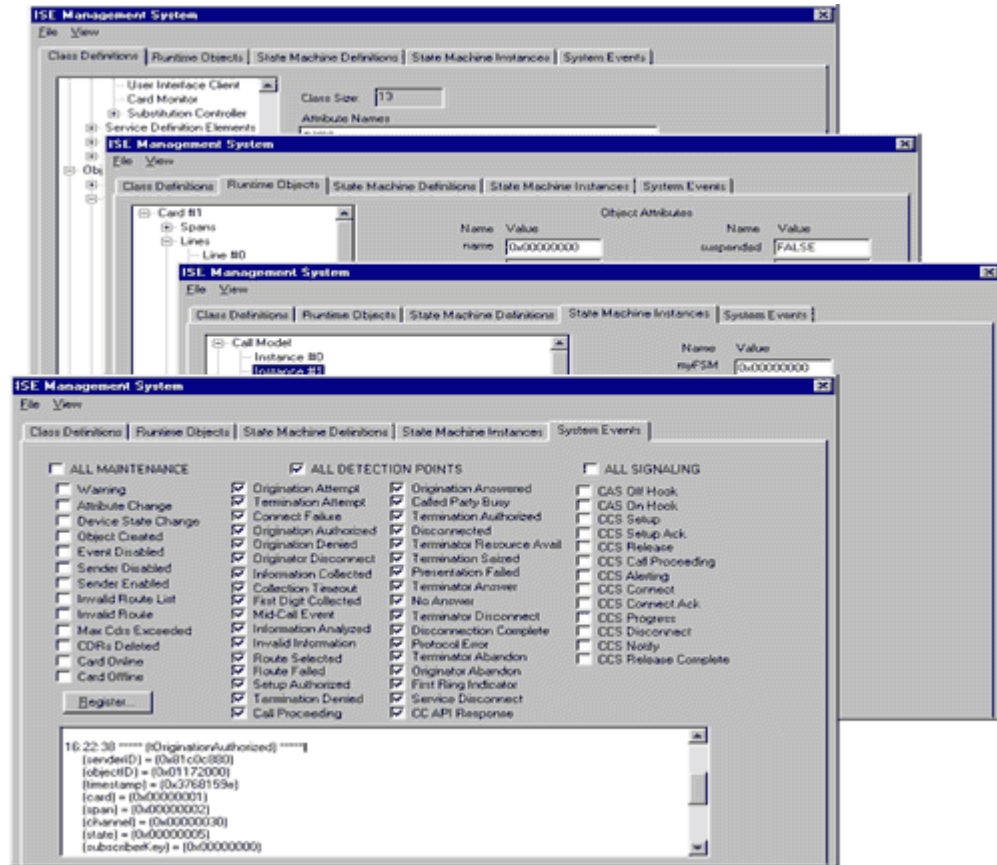

Figure 6. Graphical User Interface Software Module

## Highest Availability

Next-generation switches achieve zero downtime through hot-swappable, fault-tolerant software. These platforms never have to go into simplex mode or be brought down for software upgrades; software can be both uploaded and activated while the switch is in service. Even calls in progress are seamlessly upgraded to the new software. With next-generation switches, carriers can introduce new features and services in real-time, rather than wait until network traffic is minimal.

## 5. Flexible Deployment Options

Next-generation switches have been purpose-built with open interfaces that allow these platforms to exist in a variety of network deployments (see *Figure 7*). Next-generation switches can serve as the following:

- an alternative to traditional Class-5, end-office switches
- an alternative to traditional Class-4, tandem-office switches
- enhanced services platforms
- wireless local access switches and base station controllers
- cable telephony head end switches

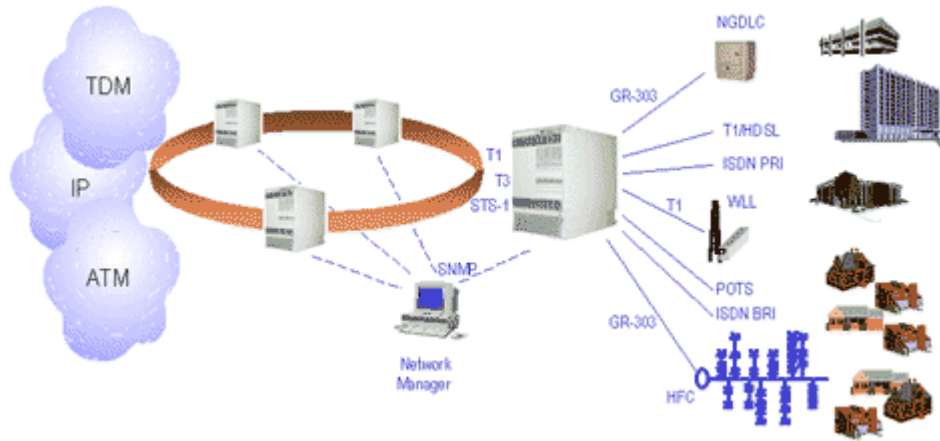

Figure 7. Next-Generation Switches in a Variety of Network Deployments

## 6. Changing the Economic Model

The most immediate and obvious benefit of these next-generation switches is their low cost. When compared to traditional Class-5 switches, next-generation switches reduce the up-front investment and offer scalability that is far less expensive and far more linear (see *Figure 8*).

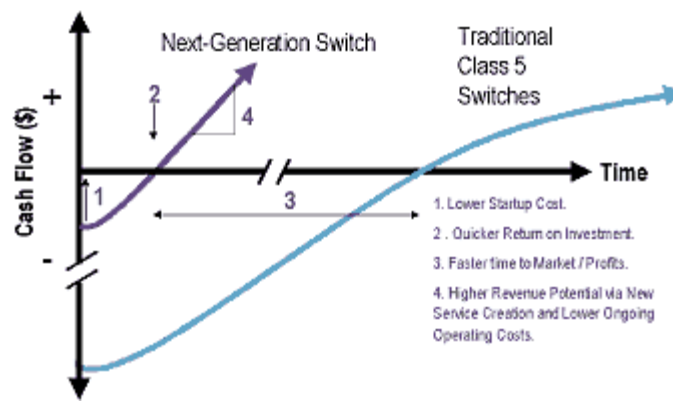

Figure 8. Switching the Economic Model

The market implications of these cost advantages are clear. With a next-generation switch, even small, start-up CLECs can afford to enter under-served secondary or tertiary markets and compete profitably. As they gain market-share, next-generation switches can be rapidly and cost-effectively scaled to meet growing demands.

### The Service Advantage

Reducing cost, however, is only part of the competitive equation. Today's subscribers demand innovative services that add value to their personal communications. The ability to create and deploy customized services that satisfy subscribers' needs is required to compete profitably.

Next-generation switches offer an advantage: flexible programmability, with enhanced service applications integrated within the switch architecture. This eliminates the need for a separate enhanced services platform in most situations, further reducing up-front costs. The open software architecture enables rapid development of new services and features and allows for third-party application development.

This flexibility, combined with the low cost and distributed nature of next-generation switches, enables network operators to create service offerings tailored to discrete subscriber bases—even in the smallest deployments. As next-generation switches offer unprecedented network integration capabilities, they allow unique service bundles, combining voice services, data services, Internet access, enhanced services, and more. The implications and benefits of this capability are clear to any network operator in a competitive situation.

### **Delivering on the Promise**

While opinions abound, the fact is that no one is certain how the multibillion-dollar telecommunications race will turn out. To compete and win in the next century, network operators will require vision and extreme flexibility. In this context, advanced next-generation switching architectures offer important advantages, providing the ability to accomplish the following tasks:

- reduce the cost and complexity of network operations by pushing switch functionality to the edge of the network
- satisfy the need for voice and data convergence, giving network operators the flexibility to take advantage of emerging technologies and standards
- protect existing network investments, while allowing network operators to cost-effectively deliver new services to new markets

Next-generation switches will provide a solid migration path from the networks of today to the converged networks of tomorrow. They offer full PSTN integration and true Class-5 switch capabilities, together with seamless integration with IP and ATM data backbones. Their open programmability enables next-generation switches to deliver customized enhanced services to discrete subscriber bases. Additionally, the low cost and high scalability of the next-generation network enable profitable operation in small and large deployments.

### **Bibliography:**

<http://www.iec.org/>