

An Introduction to Micro and Nanotechnology

by:

Joseph Ronald Cañedo

Introduction

- Nanotechnology
 - is generally considered as ranging from the smallest of these micro-scale devices down to the assembly of individual molecules to form molecular devices.
 - Two distinct overlapping fields of microelectromechanical systems (MEMS) and nanosystems or nanotechnology share a common set of engineering design considerations unique for other more typical engineering systems.
 - Two major factors the existence, effectiveness, and development of micro-scale and nano-scale transducers from those of conventional scale:
 1. Physics of scaling
 2. Suitability of manufacturing techniques and processes

Introduction

- The Physics of Scaling
 - The dominant forces that influence micro-scale devices are different from those that influence their conventional-scale counterparts.
 - This is because the size of a physical system bears a significant influence on the physical phenomena that dictate the dynamic behavior of that system.

Introduction

- General Mechanisms of Electromechanical Transduction
 - The fundamental mechanism for both sensing and actuation is energy transduction.
 - Two categories of physical electromechanical Transduction:
 1. Multicomponent transduction – utilizes “action at a distance” behavior between multiple bodies. (includes electromagnetic transduction)
 2. Deformation-based or solid-state transduction – utilizes mechanics-of-material phenomena such as crystalline phase changes or molecular dipole alignment.

Introduction

- Sensor and Actuator Transduction Characteristics
 - Characteristics of concern for both microactuator and microsensor technology are repeatability, the ability to fabricate at a small scale, immunity to extraneous influences, sufficient bandwidth , and if possible, linearity.
 - Characteristics typically of concern specifically for microactuators are achievable force, displacement, power, bandwidth (or speed of response), and efficiency.
 - Characteristics typically of concern specifically for microsensors are high resolution and the absence of drift and hysteresis.

Microactuators

- The most widely utilized multicomponent microactuators are those based upon electrostatic transduction.
- These actuators can also be regarded as a variable capacitance type, since they operate in an analogous mode to variable reluctance type electromagnetic actuators.

Microactuators

- Electrostatic actuators have been developed in both linear and rotary forms.
- Two most common configurations of the linear type of electrostatic actuator are the normal-drive and tangential or comb-drive types.

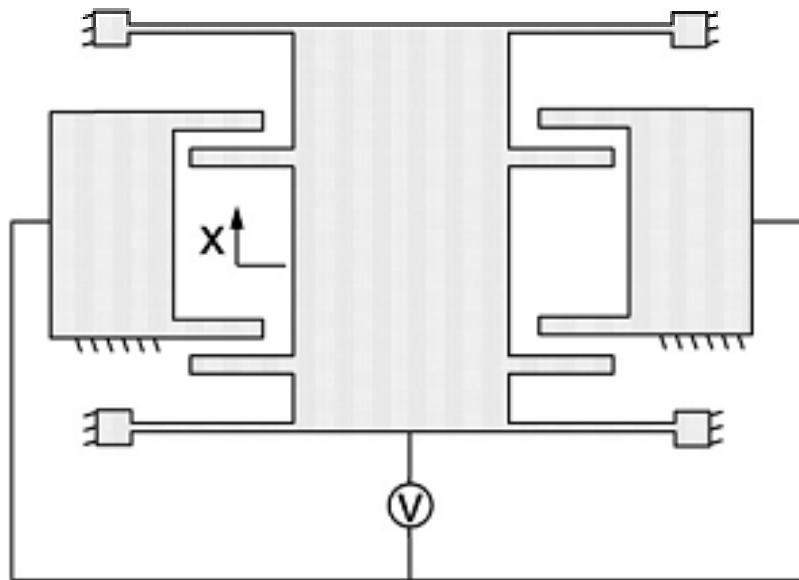

Normal-drive type

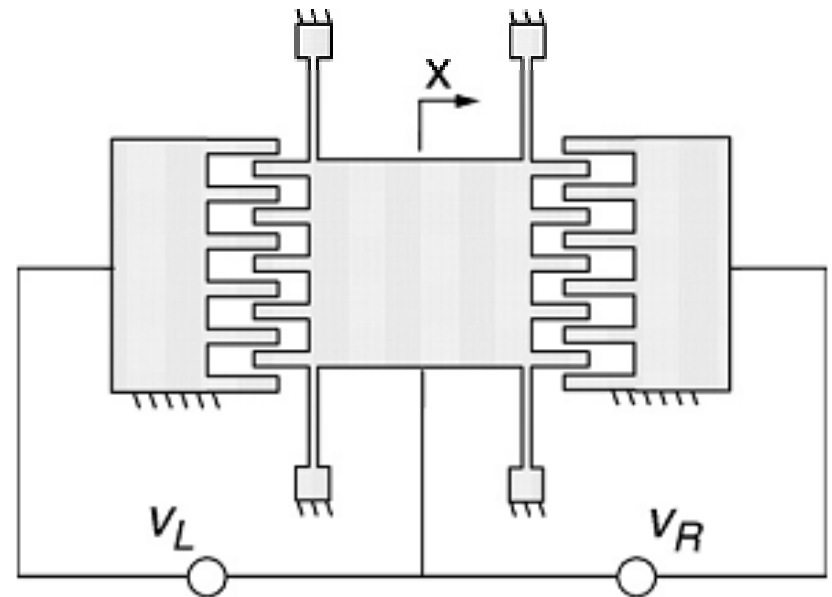

Tangential or Comb-drive type

Microactuators

- The most common configurations of rotary electrostatic actuators are the variable capacitance motor and the wobble or harmonic drive motor.

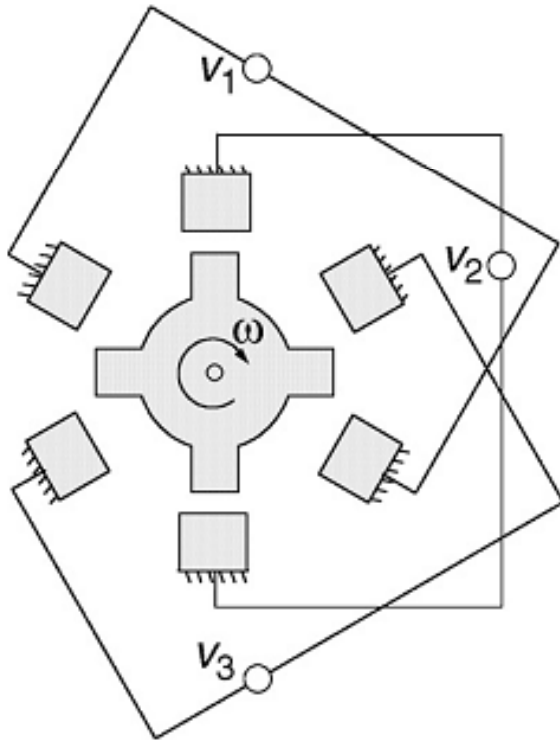

Variable capacitance motor

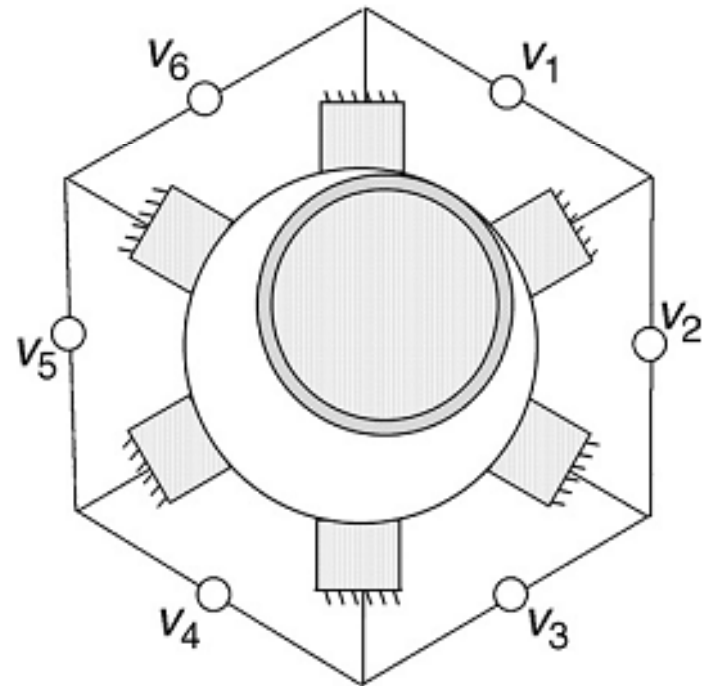

Wobble or harmonic drive motor

Microactuators

- Electromagnetic Actuation
 - Lorentz-type approached to microactuation utilize surface micromachined micro-coils.

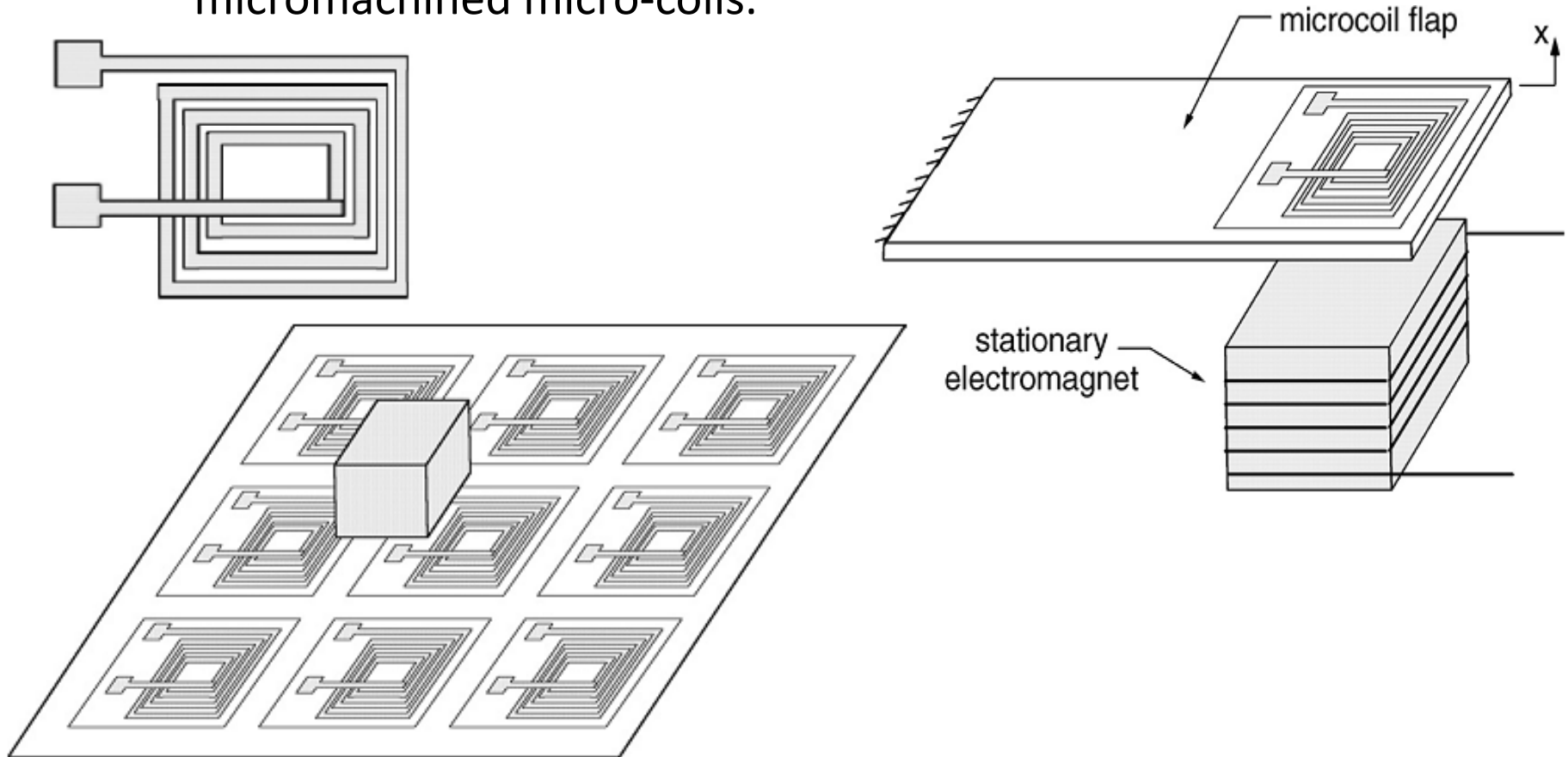

Microsensors

- Microsensors – are typically based on either measurement of mechanical strain, measurement of mechanical displacement, or on frequency measurement of a structural resonance.
 - Strain sensor
 - Pressure sensor
 - Acceleration sensor
 - Force
 - Angular rate sensing (gyroscopes)

Nanomachines

- Nanomachines are devices that range in size from the smallest of MEMS devices down to devices assembled from individual molecules.
- It introduces energy sources, structural hierarchy, and the projected future of the assembly of nanomachines.
- Built from molecular components performing individual mechanical functions, the candidates for energy sources to actuate nanomachines are limited to those that act on a molecular scale.

