

Rehabilitation Engineering and Assistive Technology

by:

Engr. Joseph Ronald Cañedo

Objectives

- Understand the role played by rehabilitation engineers and assistive technologies in the rehabilitation process.
- Be aware of the major activities in rehabilitation engineering.
- Be familiar with the physical and psychological consequences of disability.
- Know the principles of assistive technology assessment and its objectives and pitfalls.
- Discuss key engineering and ergonomic principles of the field.
- Describe career opportunities and information sources.









Introduction

- Since the late 1970s, there has been major growth in the application of technology to ameliorate the problems face by people with disabilities.
- Various terms have been used to describe this sphere of activity, including:
 1. Prosthetics /orthotics
 2. Rehabilitation engineering
 3. Assistive technology
 4. Assistive device design
 5. Rehabilitation technology, and even
 6. Biomedical engineering applied to disability.

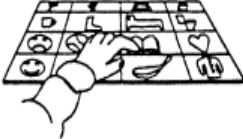
Introduction

The two most frequently used terms today are

- Assistive technology
- Rehabilitation engineering

	Direct Selection	Scanning
UnAided	 <p>Pointing and Gestures</p>	 <p>Yes/No Head Nod</p>
Low Technology	 <p>Communication Board</p>	 <p>Clock Communicator with Single Switch Input</p>
Dedicated High Technology	 <p>Communication Aid with Synthesized Speech and Printed Output</p>	 <p>Communication Aid with Single Switch Input and Synthesized Speech Output</p>
Non-Dedicated High Technology	 <p>Computer with Synthesized Speech Output</p>	 <p>Computer with Synthesized Speech Output and Single Switch Input</p>

Major Activities in Rehabilitation Engineering

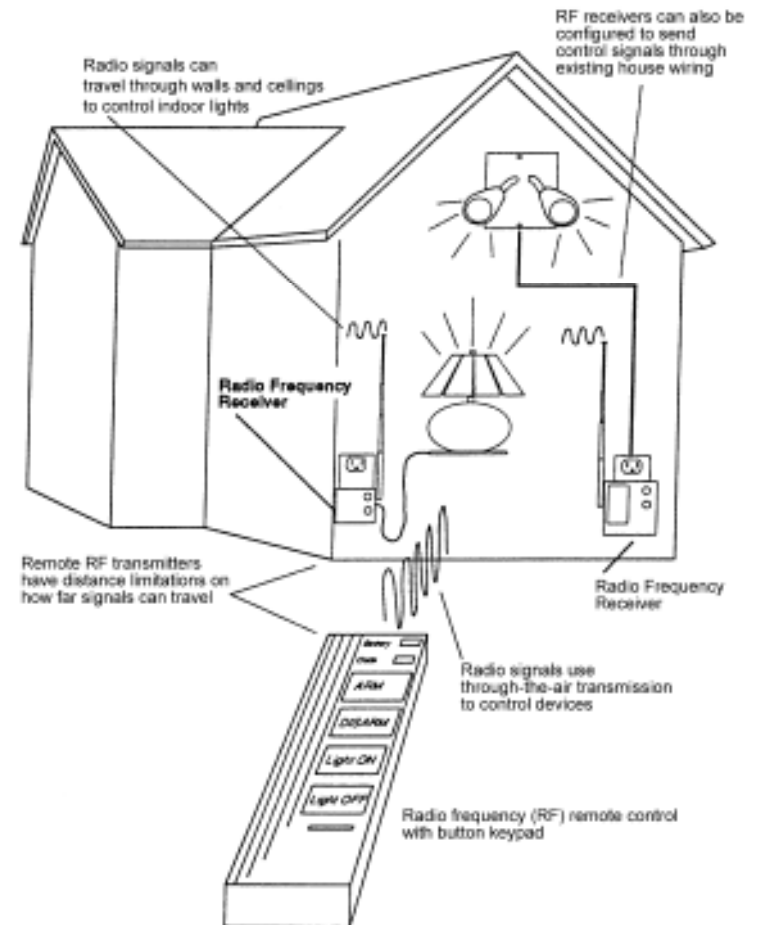
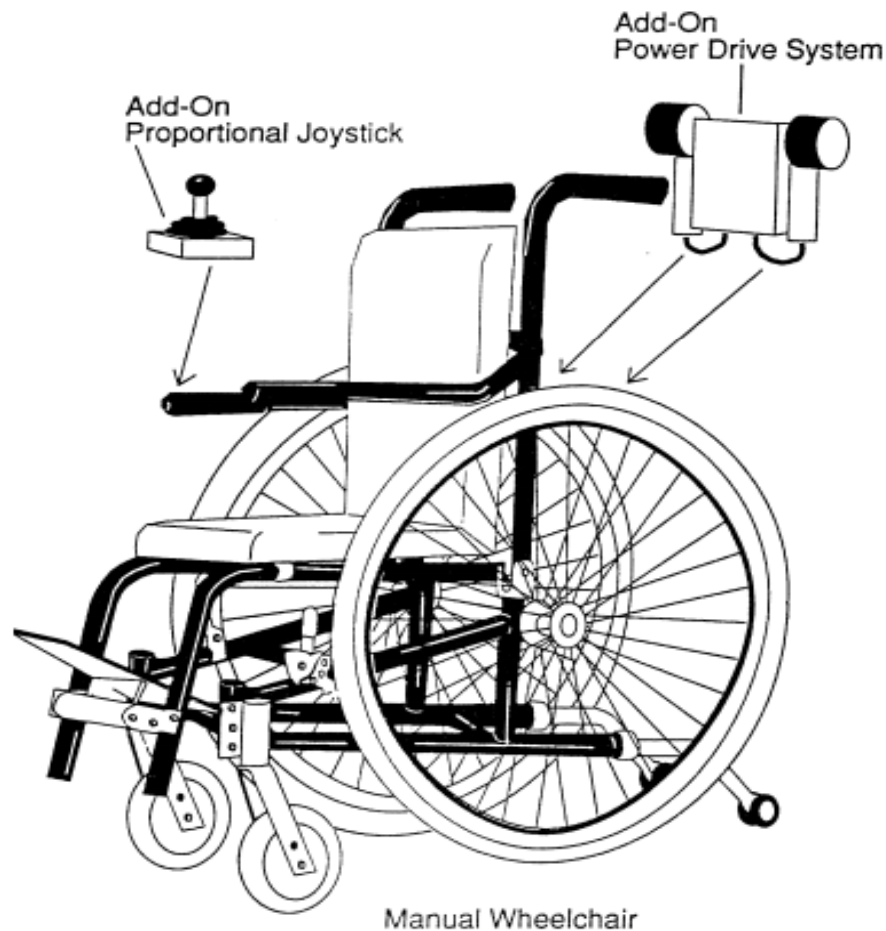

Human Component

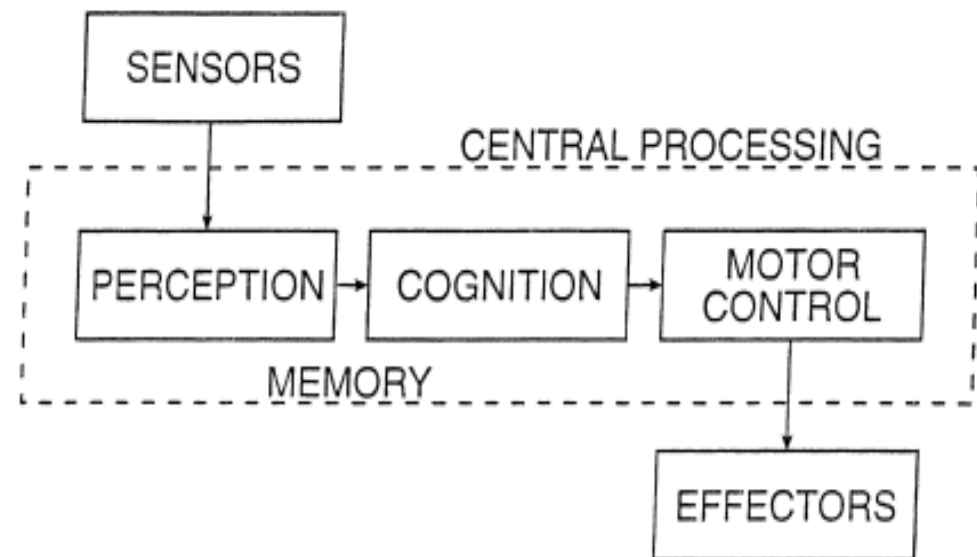
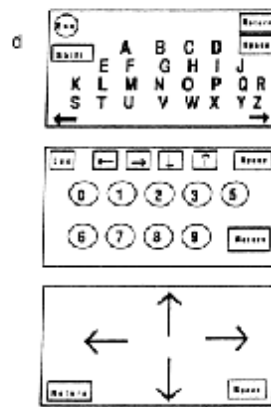
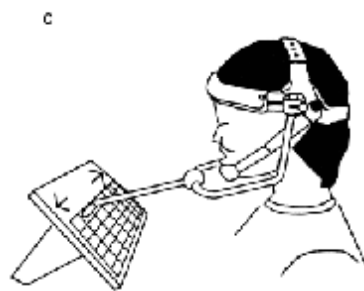
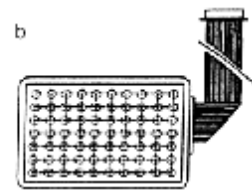

Human Component

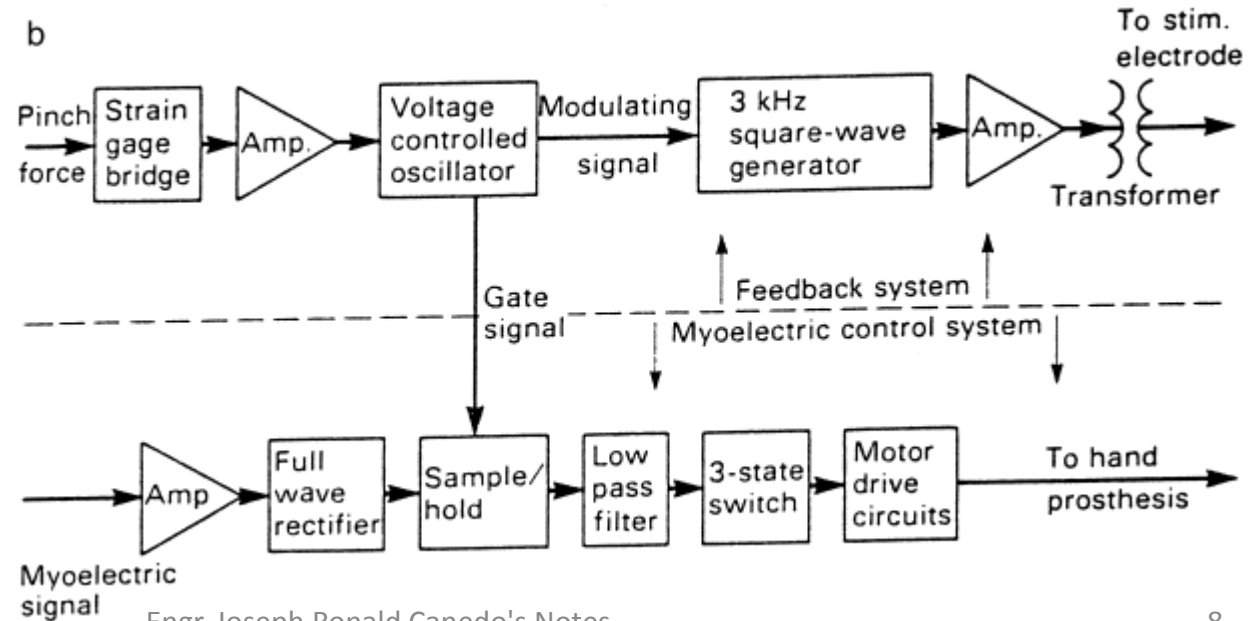
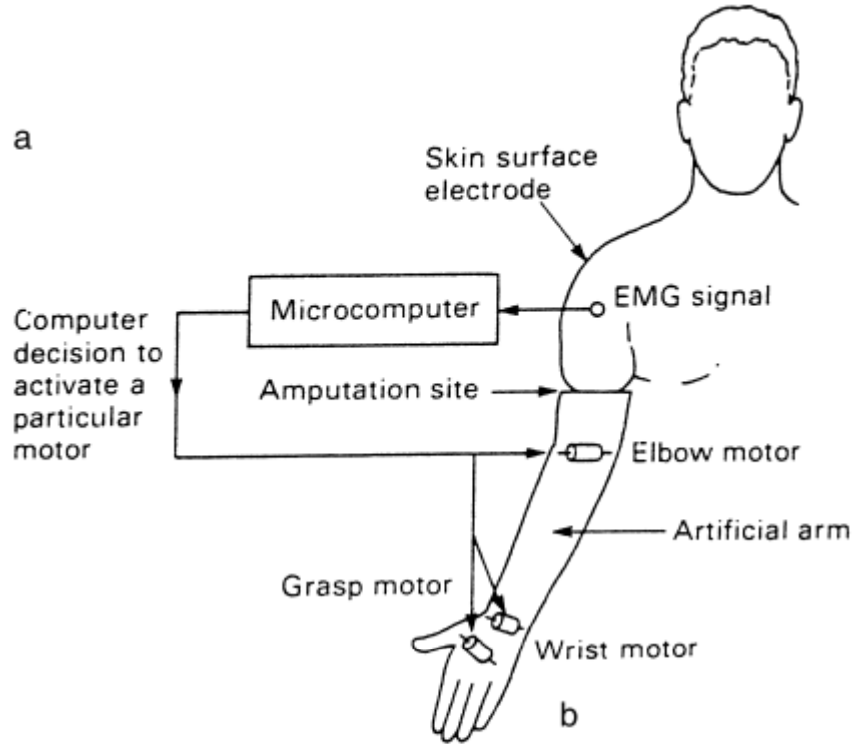

Principles of Assistive Technology Assessment

Misconception:

1. Assistive technology can solve all the problems.
2. Persons with the same disability need the same assistive devices.
3. Assistive technology is necessarily complicated and expensive.
4. Assistive technology prescription are always accurate and optimal.
5. Assistive technology will always be used.

Principles of Assistive Technology Assessment

Principles:

1. The user's goal, needs, and tasks must be clearly defined, listed, and incorporated as early as possible in the intervention process.
2. Involvement of rehabilitation professionals with differing skills and know-how will maximize the probability for a successful outcome.
3. The user's preferences, cognitive and physical abilities and limitations, living situation, tolerance for technology, and probable changes in the future must be thoroughly assessed, analyzed, and quantified.
4. Careful and thorough consideration of available of available technology for meeting the user's needs must be carried out to avoid overlooking potentially useful solutions.

Principles of Assistive Technology Assessment

Principles:

5. The user's preference and choice must be considered in the selection of the assistive technology device.
6. The assistive technology device must be customized and installed in the location and setting where it primarily will be used.
7. Not only must the user be trained to use the assistive device, but also the attendants or family members must be made aware of the device's intended purpose, benefits, and limitations.
8. Follow-up, readjustment, and reassessment of the user's usage patterns and needs are necessary at periodic intervals.

Principles of Rehabilitation Engineering

Key elements of the design process involve the following sequential steps:

1. Analysis
2. Synthesis
3. Evaluation
4. Decision
5. Implementation

Key Engineering Principles

- Wide variety of design tasks including:
 1. Worst –case design
 2. Computer simulation,
 3. Temperature effects,
 4. Reliability, and
 5. Product safety

Key Ergonomic Principles

- Principle of Proper Positioning
- Principle of the Anatomical Control Site
- Principle of Simplicity and Intuitive Operation
- Principle of Display Suitability
- Principle of Allowance for Recovery for Errors
- Principle of Adaptability and Flexibility
- Principle of Mental and Chronological Age Appropriateness

Practice of Rehabilitation Engineering and Assistive Technology

- Career Opportunities
 - In the early 1980s, the value of rehabilitation engineers and assistive technologist was unappreciated and thus required significant educational efforts for over 2 decades.
 - Currently, this profession can be found in hospital-based rehabilitation centers, public schools, vocational rehabilitation agencies, manufacturers, and community-based rehabilitation technology suppliers; opportunities also exist as independent contractors.

